

# Power pack 5 A incl. Interference filter

**Einsatz:** For the supply of the electronic and servo-motors with 24 Volt DC

**Montage:** To the wall

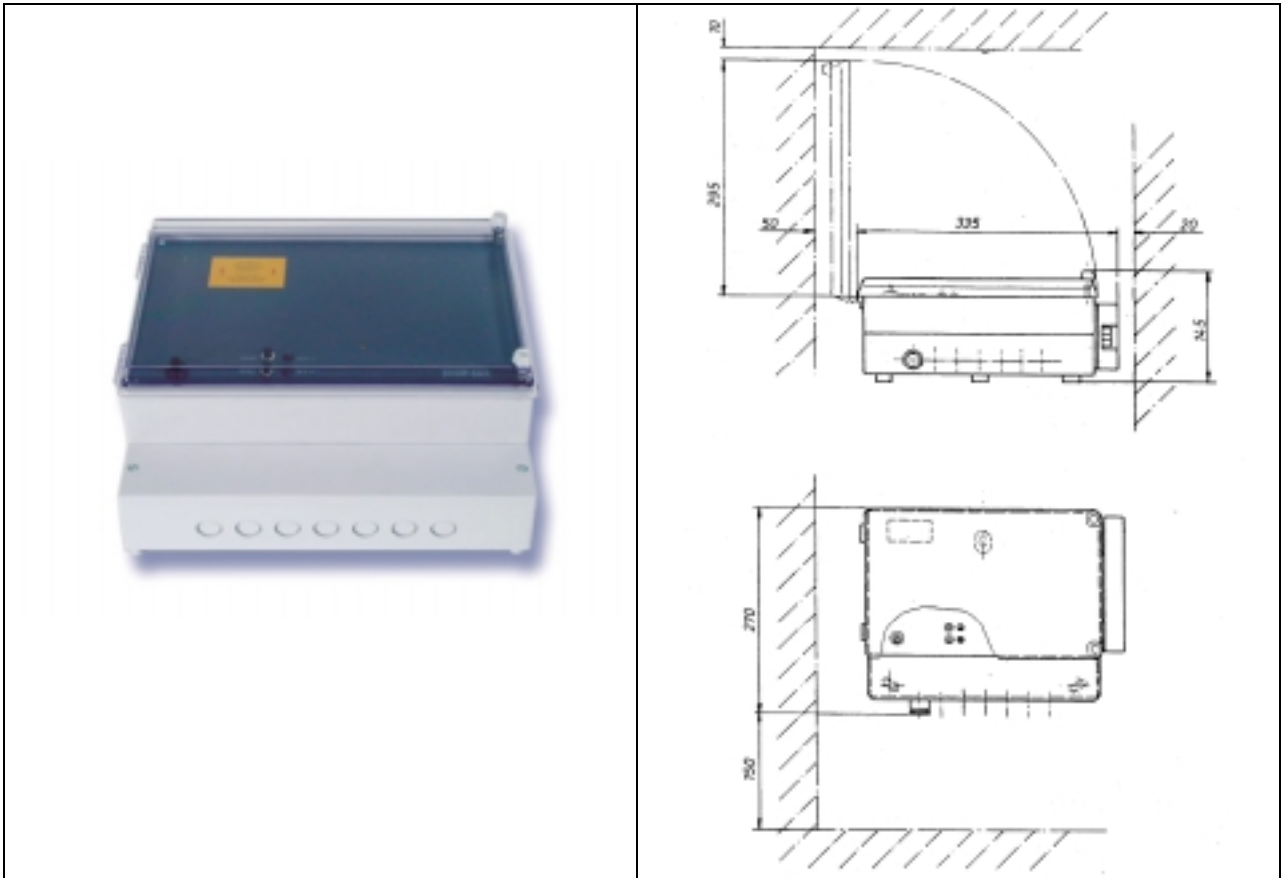

Ease of use	<ul style="list-style-type: none"> <li>• Grey plastic box with transparent cover</li> <li>• Mains switch 2-poles</li> <li>• Separate start- and reset-button</li> <li>• Red LED for function indication</li> </ul>
Technique	<ul style="list-style-type: none"> <li>• AC-input 230V, 50-60 Hz</li> <li>• DC-output 24 Volt =</li> <li>• Max. current 5 A</li> <li>• Protection type IP 20</li> </ul>
Quality	<ul style="list-style-type: none"> <li>• Toroidal-transformer for:</li> <li>• higher efficiency</li> <li>• lower weight</li> <li>• short-proof</li> </ul>